



Product Manual

Momentum Blade Server

ST94811AB





Product Manual

Momentum Blade Server

ST94811AB



©2004, Seagate Technology LLC All rights reserved
Publication number: 100339697, Rev. A
June 2004

Seagate and Seagate Technology are registered trademarks of Seagate Technology LLC. DiscWizard, SeaTools, SeaFONE, SeaBOARD, SeaTDD, 3D Defense System and the Wave logo are either registered trademarks or trademarks of Seagate Technology LLC. Other product names are registered trademarks or trademarks of their owners.

Seagate reserves the right to change, without notice, product offerings or specifications. No part of this publication may be reproduced in any form without written permission of Seagate Technology LLC.

Revision status summary sheet

Revision	Date	Sheets Affected
Rev. A	06/22/04	All.

Contents

1.0	Introduction	1
2.0	Drive specifications	3
2.1	Specification summary	3
2.2	Formatted capacity	5
2.3	Default logical geometry	5
2.4	Physical organization	5
2.5	Recording and interface technology	5
2.6	Physical characteristics	6
2.7	Seek time	6
2.8	Time to ready	6
2.9	Power specifications	7
2.9.1	Power consumption	7
2.9.2	Conducted noise	8
2.9.3	Voltage tolerance	8
2.10	Environmental specifications	9
2.10.1	Ambient temperature	9
2.10.2	Temperature gradient	9
2.10.3	Humidity	9
2.10.4	Altitude	9
2.10.5	Shock	10
2.10.6	Vibration	10
2.11	Acoustics	11
2.12	Electromagnetic immunity	11
2.13	Reliability	12
2.14	Agency certification	12
2.14.1	Safety certification	12
2.14.2	Electromagnetic compatibility	12
2.14.3	FCC verification	13
3.0	Configuring and mounting the drive	15
3.1	Handling and static discharge precautions	15
3.2	Jumper settings	15
3.2.1	Master/slave configuration	15
3.2.2	Cable-select option	16
3.3	Drive mounting	16
4.0	ATA interface	17
4.1	ATA interface signals and connector pins	17
4.1.1	Supported ATA commands	18
4.1.2	Identify Device command	20
4.1.3	Set Features command	23
4.1.4	S.M.A.R.T. commands	24
5.0	Seagate Technology support services	25

List of Figures

Figure 1.	Momentum disc drive	1
Figure 2.	Typical 5V startup and operation current profile	8
Figure 3.	Jumper settings	15
Figure 4.	Mounting dimensions—top, side and end view	16

1.0 Introduction

This manual describes the functional, mechanical and interface specifications for the Seagate® Momentus™ Blade Server drive:

- ST94811AB

These drives provide the following key features:

- 5,400-RPM spindle speed and 8 Mbytes combine for superior performance.
- Quiet operation. Fluid Dynamic Bearing (FDB) motor.
- High instantaneous (burst) data transfer rates (up to 100 Mbytes per second) using Ultra DMA mode 5.
- Giant magnetoresistive (GMR) recording heads and EPRML technology, which provide the drives with increased areal density.
- State-of-the-art cache and on-the-fly error-correction algorithms.
- Full-track multiple-sector transfer capability without local processor intervention.
- 800 Gs nonoperating shock and 225 Gs operating shock.
- SeaTools™ diagnostic software performs a drive self-test that eliminates unnecessary drive returns.
- The 3D Defense System™, which includes Drive Defense, Data Defense, and Diagnostic Defense, offers the industry's most comprehensive protection for disc drives.
- Support for S.M.A.R.T. drive monitoring and reporting.
- Support for Read Multiple and Write Multiple commands.
- Support for autodetection of master/slave drives that use cable select (CSEL).

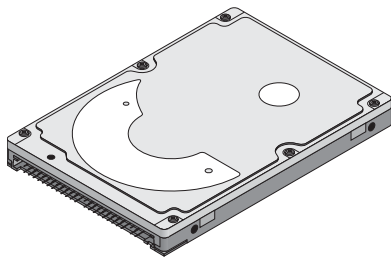

Figure 1. Momentus disc drive

2.0 Drive specifications

Unless otherwise noted, all specifications are measured under ambient conditions, at 25°C, and nominal power. For convenience, the phrases *the drive* and *this drive* are used throughout this manual to indicate ST94811AB model drives.

2.1 Specification summary

The specifications listed in this table are for quick reference. For details on specification measurement or definition, see the appropriate section of this manual.

Table 1: Specifications

Drive specification	ST94811AB
Formatted Gbytes (512 bytes/sector)	40
Guaranteed sectors	78,140,160
Bytes per sector	512
Physical read/write heads	2
Discs	1
Cache (Mbytes)	2
Recording density, BPI (bits/inch max)	642,000
Track density, TPI (tracks/inch max)	100,780
Areal density (Mbits/inch ² max)	65
Spindle speed (RPM)	5,400
Internal data transfer rate OD (Mbytes/sec max)	48.25
Sustained data transfer rate OD (Mbytes/sec)	34.5
I/O data transfer rate (Mbytes/sec max)	100
ATA data transfer modes supported	PIO modes 0–4; Multiword DMA modes 0–2; Ultra DMA modes 0–5
Height	9.5 +/-0.2 mm (0.374 +/-0.0078 inches)
Width	69.85 +/-0.25 mm (2.75 +/-0.0098 inches)
Length	100.2 +/-0.25 mm (3.945 +/-0.0098 inches)
Weight (typical)	99 grams (0.218 lb.)
Average latency (msec)	5.6
Power-on to ready (sec typical)	3.9
Standby to ready (sec typical)	2.6 sec
Startup current 5V (peak)	1.2 amps
Track-to-track seek time (msec typical)	1.5 (read), 2.0 (write)
Average seek time (msec typical)	12.0
Average seek, read (msec typical)	12.0
Average seek, write (msec typical)	14.0

Table 1: Specifications (Continued)

Drive specification	ST94811AB
Full-stroke seek (msec)	22 (typical); 26 (max)
Seek power (typical)	2.4 watts
Read/write power (typical)	2.4 watts
Idle, performance mode (typical)	2.5 watts
Standby mode	0.36 watts (typical)**
Sleep mode	0.36 watts (typical)**
Voltage tolerance (including noise)	5V ± 5%
Ambient temperature	5° to 55°C (operating) -40° to 65°C (nonoperating)
Temperature gradient (°C per hour max)	20°C (operating) 30°C (nonoperating)
Relative humidity (noncondensing)	5% to 90% (operating) 5% to 95% (nonoperating)
Relative humidity gradient	30% per hour max
Wet bulb temperature (°C max)	33°C (operating) 40°C (nonoperating)
Altitude, operating	-192.12 m to 3,048 m (-650 ft to 10,000+ ft)
Altitude, nonoperating (below mean sea level, max)	-304.8 m to 12,192 m (-1,000 ft to 40,000+ ft)
Shock, operating (Gs max at 2 msec)	225
Shock, nonoperating (Gs max at 2 msec)	800
Shock, nonoperating (Gs max at 1 msec)	800
Shock, nonoperating (Gs max at 0.5 msec)	400
Vibration, operating (max displacement may apply below 10 hz)	1.0 Gs (0 to peak, 5–500 Hz)
Vibration, nonoperating (max displacement may apply below 22 hz)	5.0 Gs (0 to peak, 5–500 Hz)
Drive acoustics, sound power (bels)	
Idle*	2.3 (typical) 2.5 (max)
Performance seek	3.0 (typical) 3.2 (max)
Nonrecoverable read errors	1 per 10 ¹⁴ bits read
Mean time between failures (power-on hours)	500,000 at 25°C (8,760 POH/year) Max case temperature: 40°C
Load/Unload (U/UL) cycles	
25°C, 50% relative humidity	300,000 software-controlled power on/off cycles 20,000 hard power on/off cycles
32°C, 80% relative humidity	100,000 software-controlled power on/off cycles
5°C, 80% relative humidity	20,000 hard power on/off cycles
5°C, 10% relative humidity	
55°C, 16% relative humidity	
Service life	5 years
Warranty	1 year

*During periods of drive idle, some offline activity may occur according to the S.M.A.R.T. specification, which may increase acoustic and power to operational levels.

**Typical notebooks will pull power to the drive when entering S3 and S4; while in the S3 and S4 states, drive sleep and drive standby modes will not contribute to battery power consumption.

2.2 Formatted capacity

Model	Formatted capacity	Guaranteed sectors	Bytes per sector
ST94811AB	40 Gbytes	78,140,160	512

2.3 Default logical geometry

Cylinders	Read/write heads	Sectors per track
16,383	16	63

LBA mode

When addressing these drives in LBA mode, all blocks (sectors) are consecutively numbered from 0 to $n-1$, where n is the number of guaranteed sectors as defined above.

2.4 Physical organization

Model	Read/write heads	Number of discs
ST94811AB	2	1

2.5 Recording and interface technology

Technology	Specification
Interface	Parallel ATA
Recording method	RLL 0,11
Recording density BPI (bits/inch max)	642,000
Track density TPI (tracks/inch max)	100,780
Areal density (Mbits/inch ² max)	65
Spindle speed (RPM) ($\pm 0.2\%$)	5,400
Internal data transfer rate OD (Mbytes/sec max)	48.25
Sustained data transfer rate OD (Mbytes/sec max)	34.5
I/O data transfer rate (Mbytes/sec max)	100 (Ultra DMA mode 5)
Interleave	1:1
Cache buffer ST94811AB	8 Mbytes (8,192 kbytes)

2.6 Physical characteristics

Height	(mm) (inches)	9.5 +/-0.2 0.374 +/-0.0078
Width	(mm) (inches)	69.85 +/-0.25 2.75 +/-0.0098
Length	(mm) (inches)	100.2 +/-0.25 3.945 +/-0.0098
Typical weight	(grams) (pounds)	99 0.218

2.7 Seek time

Seek measurements are taken with nominal power at 25°C ambient temperature. All times are measured using drive diagnostics. The specifications below are defined as follows:

- Track-to-track seek time is an average of all possible single-track seeks in both directions.
- Average seek time is a true statistical random average of at least 5,000 measurements of seeks between random tracks, less overhead.

Typical seek times (msec)*	Read	Write
Track-to-track	1.5	2.0
Average	12.0	14.0
Full-stroke	22.0	26.0
Average latency	5.6	5.6

*Measured in performance mode

Note. These drives are designed to consistently meet the seek times represented in this manual. Physical seeks, regardless of mode (such as track-to-track and average), are expected to meet or exceed the noted values. However, due to the manner in which these drives are formatted, benchmark tests that include command overhead or measure logical seeks may produce results that vary from these specifications.

2.8 Time to ready

Time to ready	Typical	Max
Power-on to Ready (sec)	3.9	8
Standby to Ready (sec)	2.6	8

2.9 Power specifications

The drive receives DC power (+5V) through the interface connector.

2.9.1 Power consumption

Power requirements for the drives are listed in the table on page 7. Typical power measurements are based on an average of drives tested, under nominal conditions, using 5.0V input voltage at 25°C ambient temperature.

- **Spinup power**

Spinup power is measured from the time of power-on to the time that the drive spindle reaches operating speed.

- **Seek mode**

During seek mode, the read/write actuator arm moves toward a specific position on the disc surface and does not execute a read or write operation. Servo electronics are active. Seek mode power is measured based on three random seek operations every 100 msecs. This mode is not typical.

- **Read/write power and current**

Read/write power is measured with the heads on track, based on three 63 sector read or write operations every 100 msecs.

- **Operating power and current**

Operating power is measured using 40 percent random seeks, 40 percent read/write mode (1 write for each 10 reads) and 20 percent drive idle mode.

- **Idle mode power**

Idle mode power is measured with the drive up to speed, with servo electronics active and with the heads in a random track location.

- **Standby mode**

During Standby mode, the drive accepts commands, but the drive is not spinning, and the servo and read/write electronics are in power-down mode.

Table 2: DC power

Power dissipation (watts)	Average (watts, 25° C)	5V typ amps
Spinup	—	1.2
Idle, performance mode	2.50	0.5
Operating 40% r/w. 40% seek, 20% inop.	2.87	0.72
Seeking	2.4	0.48
Read	2.4	0.48
Write	2.4	0.48
Standby	0.36	0.07
Sleep	0.36	0.07

*During periods of drive idle, some offline activity may occur according to the S.M.A.R.T. specification, which may increase acoustic and power to operational levels.

2.9.1.1 Typical current profile

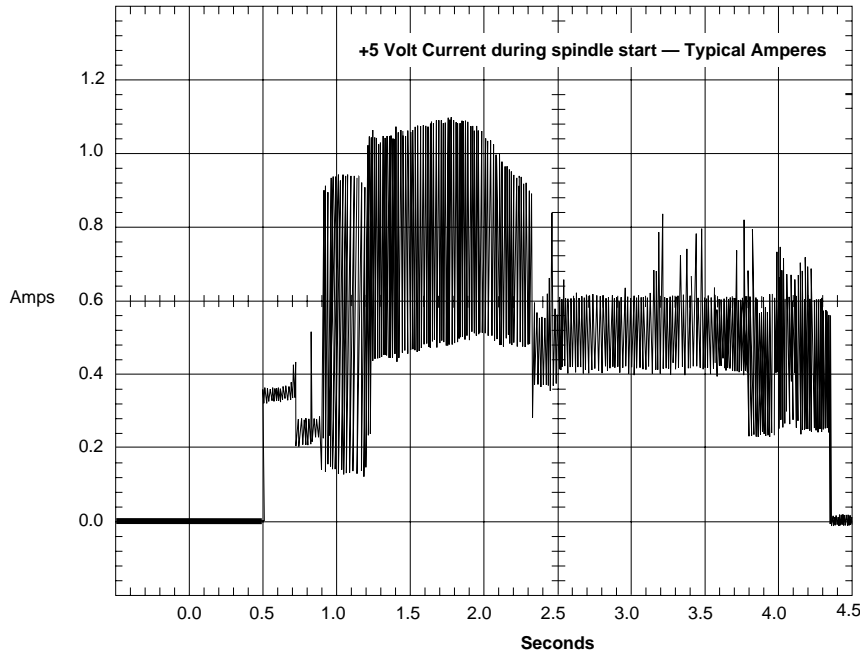

Figure 2. Typical 5V startup and operation current profile

2.9.2 Conducted noise

Input noise ripple is measured at the host system power supply across an equivalent 15-ohm resistive load on the +5 volt line.

Using 5-volt power, the drive is expected to operate with a maximum of 100 mV peak-to-peak square-wave injected noise at up to 10 MHz.

Note. Equivalent resistance is calculated by dividing the nominal voltage by the typical RMS read/write current.

2.9.3 Voltage tolerance

Voltage tolerance (including noise):

5V \pm 5%

2.10 Environmental specifications

2.10.1 Ambient temperature

Ambient temperature is defined as the temperature of the environment immediately surrounding the drive. Actual drive case temperature should not exceed 40°C (104°F) within the operating ambient conditions.

Above 1,000 feet (305 meters), the maximum temperature is derated linearly by 1°C every 1000 feet.

Operating	5° to 55°C (41° to 131°F)
Nonoperating	-40° to 65°C (-40° to 153°F)

2.10.2 Temperature gradient

Operating	20°C per hour (68°F per hour max), without condensation
Nonoperating	30°C per hour (86°F per hour max)

2.10.3 Humidity

2.10.3.1 Relative humidity

Operating	5% to 90% noncondensing (30% per hour max)
Nonoperating	5% to 95% noncondensing (30% per hour max)

2.10.3.2 Wet bulb temperature

Operating	33°C (91.4°F max)
Nonoperating	40°C (104°F max)

2.10.4 Altitude

Operating	-198.12 m to 3,048 m (-650 ft to 10,000+ ft)
Nonoperating	-304.8 to 12,192 m (-1,000 ft to 40,000+ ft)

2.10.5 Shock

All shock specifications assume that the drive is mounted securely with the input shock applied at the drive mounting screws. Shock may be applied in the X, Y, or Z axis.

2.10.5.1 Operating shock

These drives comply with the performance levels specified in this document when subjected to a maximum operating shock of 225 Gs based on half-sine shock pulses of 2 msec. Shocks should not be repeated more than two times per second.

2.10.5.2 Nonoperating shock

The nonoperating shock level that the drive can experience without incurring physical damage or degradation in performance when subsequently put into operation is 800 Gs based on a nonrepetitive half-sine shock pulse of 2 msec duration.

The nonoperating shock level that the drive can experience without incurring physical damage or degradation in performance when subsequently put into operation is 800 Gs based on a nonrepetitive half-sine shock pulse of 1 msec duration.

The nonoperating shock level that the drive can experience without incurring physical damage or degradation in performance when subsequently put into operation is 400 Gs based on a nonrepetitive half-sine shock pulse of 0.5 msec duration.

2.10.6 Vibration

All vibration specifications assume that the drive is mounted securely with the input vibration applied at the drive mounting screws. Vibration may be applied in the X, Y, or Z axis.

2.10.6.1 Operating vibration

The following table lists the maximum vibration levels that the drive may experience while meeting the performance standards specified in this document.

5–500 Hz	1.0 Gs (0 to peak). Max displacement may apply below 10 Hz.
----------	---

2.10.6.2 Nonoperating vibration

The following table lists the maximum nonoperating vibration that the drive may experience without incurring physical damage or degradation in performance when subsequently put into operation.

5–500 Hz	5.0 Gs (0 to peak). Max displacement may apply below 22 Hz.
----------	---

2.11 Acoustics

Drive acoustics are measured as overall A-weighted acoustic sound power levels (no pure tones). All measurements are consistent with ISO document 7779. Sound power measurements are taken under essentially free-field conditions over a reflecting plane. For all tests, the drive is oriented with the cover facing upward.

Note. For seek mode tests, the drive is placed in seek mode only. The number of seeks per second is defined by the following equation:

$$(\text{Number of seeks per second} = 0.4 / (\text{average latency} + \text{average access time}))$$

Table 3: Drive level acoustics

Acoustic mode	
Idle*	Performance Seek
2.3 bels (typ) 2.5 bels (max)	3.0 bels (typ) 3.2 bels (max)

*During periods of drive idle, some offline activity may occur according to the S.M.A.R.T. specification, which may increase acoustic and power to operational levels.

2.12 Electromagnetic immunity

When properly installed in a representative host system, the drive operates without errors or degradation in performance when subjected to the radio frequency (RF) environments defined in the following table:

Table 4: Electromagnetic immunity

Test	Description	Performance level	Reference standard
Electrostatic discharge	Contact, HCP, VCP: ± 4 kV; Air: ± 8 kV	B	EN 61000-4-2: 95
Radiated RF immunity	80 to 1,000 MHz, 3 V/m, 80% AM with 1 kHz sine 900 MHz, 3 V/m, 50% pulse modulation @ 200 Hz	A	EN 61000-4-3: 96 ENV 50204: 95
Electrical fast transient	± 1 kV on AC mains, ± 0.5 kV on external I/O	B	EN 61000-4-4: 95
Surge immunity	± 1 kV differential, ± 2 kV common, AC mains	B	EN 61000-4-5: 95
Conducted RF immunity	150 kHz to 80 MHz, 3 Vrms, 80% AM with 1 kHz sine	A	EN 61000-4-6: 97
Voltage dips, interrupts	0% open, 5 seconds 0% short, 5 seconds 40%, 0.10 seconds 70%, 0.01 seconds	C C C B	EN 61000-4-11: 94

2.13 Reliability

Measurement type	Specification
Nonrecoverable read errors	1 per 10 ¹⁴ bits read, max.
Mean time between failures	500,000 power-on hours (8,760 POH/year) At nominal power, 25°C ambient temperature. Max case temperature: 40°C at the case measurement location shown in Figure 4.
Load/Unload (U/UL) 25°C, 50% relative humidity 32°C, 80% relative humidity 5°C, 80% relative humidity 5°C, 10% relative humidity 55°C, 16% relative humidity	 300,000 software-controlled power on/off cycles 20,000 hard power on/off cycles 100,000 software-controlled power on/off cycles 20,000 hard power on/off cycles
Service life	5 years
Warranty	1 year

2.14 Agency certification

2.14.1 Safety certification

The drives are recognized in accordance with UL 1950 and CSA C22.2 (950) and meet all applicable sections of IEC950 and EN 60950 as tested by TUV North America.

2.14.2 Electromagnetic compatibility

Hard drives that display the CE mark comply with the European Union (EU) requirements specified in the Electromagnetic Compatibility Directive (89/336/EEC). Testing is performed to the levels specified by the product standards for Information Technology Equipment (ITE). Emission levels are defined by EN 55022, Class B and the immunity levels are defined by EN 55024.

Seagate uses an independent laboratory to confirm compliance with the EC directives specified in the previous paragraph. Drives are tested in representative end-user systems. Although CE-marked Seagate drives comply with the directives when used in the test systems, we cannot guarantee that all systems will comply with the directives. The drive is designed for operation inside a properly designed enclosure, with properly shielded I/O cable (if necessary) and terminators on all unused I/O ports. Computer manufacturers and system integrators should confirm EMC compliance and provide CE marking for their products.

Korean RRL

If these drives have the Korea Ministry of Information and Communication (MIC) logo, they comply with paragraph 1 of Article 11 of the Electromagnetic Compatibility control Regulation and meet the Electromagnetic Compatibility (EMC) Framework requirements of the Radio Research Laboratory (RRL) Ministry of Information and Communication Republic of Korea.

These drives have been tested and comply with the Electromagnetic Interference/Electromagnetic Susceptibility (EMI/EMS) for Class B products. Drives are tested in a representative, end-user system by a Korean-recognized lab.

- EUT name (model number): ST94811AB.
- Certificate numbers:
ST94811AB E-H011-03-1189(B)
- Trade name or applicant: Seagate Technology
- Manufacturing date: June 2004
- Manufacturer/nationality: USA and Singapore

Australian C-Tick (N176)

If these models have the C-Tick marking, they comply with the Australia/New Zealand Standard AS/NZS3548 1995 and meet the Electromagnetic Compatibility (EMC) Framework requirements of the Australian Communication Authority (ACA).

2.14.3 FCC verification

These drives are intended to be contained solely within a personal computer or similar enclosure (not attached as an external device). As such, each drive is considered to be a subassembly even when it is individually marketed to the customer. As a subassembly, no Federal Communications Commission verification or certification of the device is required.

Seagate Technology LLC has tested this device in enclosures as described above to ensure that the total assembly (enclosure, disc drive, motherboard, power supply, etc.) does comply with the limits for a Class B computing device, pursuant to Subpart J, Part 15 of the FCC rules. Operation with noncertified assemblies is likely to result in interference to radio and television reception.

Radio and television interference. This equipment generates and uses radio frequency energy and if not installed and used in strict accordance with the manufacturer's instructions, may cause interference to radio and television reception.

This equipment is designed to provide reasonable protection against such interference in a residential installation. However, there is no guarantee that interference will not occur in a particular installation. If this equipment does cause interference to radio or television, which can be determined by turning the equipment on and off, you are encouraged to try one or more of the following corrective measures:

- Reorient the receiving antenna.
- Move the device to one side or the other of the radio or TV.
- Move the device farther away from the radio or TV.
- Plug the computer into a different outlet so that the receiver and computer are on different branch outlets.

If necessary, you should consult your dealer or an experienced radio/television technician for additional suggestions. You may find helpful the following booklet prepared by the Federal Communications Commission: *How to Identify and Resolve Radio-Television Interference Problems*. This booklet is available from the Superintendent of Documents, U.S. Government Printing Office, Washington, DC 20402. Refer to publication number 004-000-00345-4.

3.0 Configuring and mounting the drive

This section contains the specifications and instructions for configuring and mounting the drive.

3.1 Handling and static discharge precautions

After unpacking, and before installation, the drive may be exposed to potential handling and electrostatic discharge (ESD) hazards. Observe the following standard handling and static-discharge precautions:

Caution:

- Keep the drive in the electrostatic discharge (ESD) bag until you are ready for installation to limit the drive's exposure to ESD.
- Before handling the drive, put on a grounded wrist strap, or ground yourself frequently by touching the metal chassis of a computer that is plugged into a grounded outlet. Wear a grounded wrist strap throughout the entire installation procedure.
- Handle the drive only by its edges or frame.
- The drive is fragile—handle it with care. Do not press down on the drive top cover.
- Always rest the drive on a padded, antistatic surface until you mount it in the computer.
- Do not touch the connector pins or the printed circuit board.
- Do not remove the factory-installed labels from the drive or cover them with additional labels. Removal voids the warranty. Some factory-installed labels contain information needed to service the drive. Other labels are used to seal out dirt and contamination.

3.2 Jumper settings

3.2.1 Master/slave configuration

Use the options jumper block shown in Figure 3 to configure the drive for operation. This jumper block is the 4-pin header adjacent to pins 1 and 2 of the I/O signal pins. For additional information about using the Cable select option, see Section 3.2.2.

The “Master or single drive” option is the factory default setting.

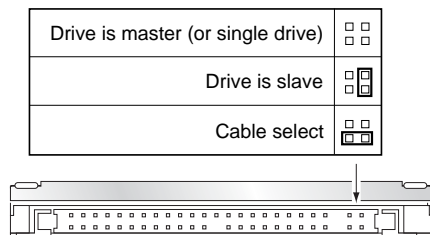

Figure 3. Jumper settings

3.2.2 Cable-select option

Computers that use cable select determine the master and slave drives by selecting or deselecting pin 28, CSEL, on the interface bus. Master and slave drives are determined by their physical position on the cable. To enable cable select, set a jumper as shown in Figure 3. Refer to your computer manual to determine whether your computer supports this option.

3.3 Drive mounting

You can mount the drive using four screws in the side-mounting holes or four screws in the bottom-mounting holes. See Figure 4 for drive mounting dimensions. Follow these important mounting precautions when mounting the drive:

- Allow a minimum clearance of 0.030 inches (0.76 mm) around the entire perimeter of the drive for cooling.
- Use only M3 UNC mounting screws.
- Do not overtighten the mounting screws (maximum torque: 4.0 inch-lb).
- Four (4) threads (0.080 inches) minimum screw engagement recommended.

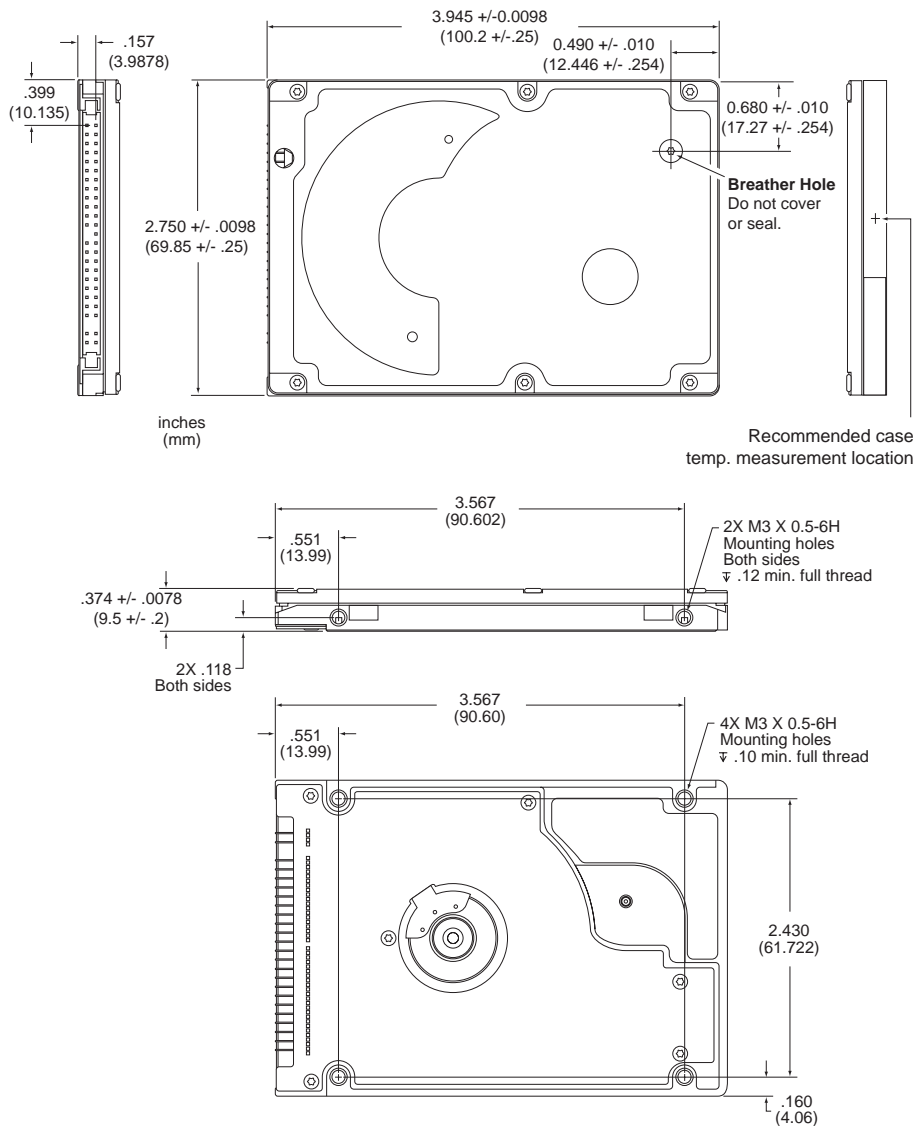

Figure 4. Mounting dimensions—top, side and end view

4.0 ATA interface

These drives use the industry-standard ATA task file interface that supports 16-bit data transfers. It supports ATA programmed input/output (PIO) modes 0–4; multiword DMA modes 0–2, and Ultra DMA modes 0–5. The drive also supports the use of the IORDY signal to provide reliable high-speed data transfers.

For detailed information about the ATA interface, refer to the draft of *AT Attachment with Packet Interface Extension (ATA/ATAPI-6)*, *NCITS T13 1410D*, subsequently referred to as the *Draft ATA-6 Standard*.

4.1 ATA interface signals and connector pins

The following table summarizes the signals on the 44-pin ATA interface connector. For a detailed description of these signals, refer to the *Draft ATA-6 Standard*.

Table 5: Connector signals

Signal Name	Connector Contact	Cable Conductor
RESET-	1	1
DD7	3	3
DD6	5	5
DD5	7	7
DD4	9	9
DD3	11	11
DD2	13	13
DD1	15	15
DD0	17	17
Ground	19	19
DMARQ	21	21
DIOW-	23	23
DIOR-	25	25
IORDY	27	27
DMACK-	29	29
INTRQ	31	31
DA1	33	33
DA0	35	35
CS1FX-	37	37
DASP-	39	39
+5 V (Logic)	41	41
Ground (Return)	43	43

Cable Conductor	Connector Contact	Signal Name
2	2	Ground
4	4	DD8
6	6	DD9
8	8	DD10
10	10	DD11
12	12	DD12
14	14	DD13
16	16	DD14
18	18	DD15
20	20	(keypin)
22	22	Ground
24	24	Ground
26	26	Ground
28	28	PSYNC:CSEL
30	30	Ground
32	32	IOCS16-
34	34	PDIAG-
36	36	DA2
38	38	CS3FX-
40	40	Ground
42	42	+5V (Motor)
44	44	No connection

4.1.1 Supported ATA commands

The following table lists ATA-standard commands that the drive supports. For a detailed description of the ATA commands, refer to the *Draft ATA-6 Standard*. See “S.M.A.R.T commands” on page 24 for details and subcommands used in the S.M.A.R.T. implementation.

Table 6: Supported commands

Command name	Command code (in hex)
ATA-standard commands	
ATA Device Configuration Overlay	B1 _H
ATA Service	A2 _H
Check Power Mode	98 _H , E5 _H
Download Microcode	92 _H
Execute Device Diagnostics	90 _H
Flush Cache	E7 _H
Flush Cache Extended	EA _H
Format Track (Legacy)	50 _H
Identify Device	EC _H
Idle	97 _H , E3 _H
Idle Immediate	95 _H , E1 _H
Initialize Device Parameters	91 _H
Read Buffer	E4 _H
Read DMA	C8 _H , C9 _H
Read DMA Extended	25 _H
Read Log Extended	22 _H
Read Multiple	C4 _H
Read Multiple Extended	29 _H
Read Native Max Address	F8 _H
Read Native Max Address Extended	27 _H
Read Sectors	20 _H , 21 _H
Read Sectors Extended	24 _H
Read Verify Sectors	40 _H , 41 _H
Read Verify Sectors Extended	42 _H
Recalibrate	10 _H
Security Disable Password	F6 _H
Security Erase Prepare	F3 _H
Security Erase Unit	F4 _H
Security Freeze Lock	F5 _H
Security Set Password	F1 _H

Table 6: Supported commands (Continued)

Command name	Command code (in hex)
Security Unlock	F2 _H
Seek	70 _H
Set Drive Parameters	91 _H
Set Features	EF _H
Set Max Address	F9 _H
Note: Individual Set Max commands are identified by the value placed in the Set Max Features register as defined to the right.	Address: 00 _H Password: 01 _H Lock: 02 _H Unlock: 03 _H Freeze Lock: 04 _H
Set Multiple Mode	C6 _H
Sleep	99 _H , E6 _H
S.M.A.R.T.	B0 _H
Standby	96 _H , E2 _H
Standby Immediate	94 _H , E0 _H
Vendor Unique	9A _H , FA _H , FB _H
Write Buffer	E8 _H
Write DMA	CA _H , CB _H
Write DMA Extended	35 _H
Write Log Extended	32 _H
Write Multiple	C5 _H
Write Multiple Extended	39 _H
Write Sectors	30 _H , 31 _H
Write Sectors Extended	34 _H
ATA-standard power-management commands	
Check Power Mode	98 _H or E5 _H
Idle	97 _H or E3 _H
Idle Immediate	95 _H or E1 _H
Sleep	99 _H or E6 _H
Standby	96 _H or E2 _H
Standby Immediate	94 _H or E0 _H
ATA-standard security commands	
Security Set Password	F1 _H
Security Unlock	F2 _H
Security Erase Prepare	F3 _H
Security Erase Unit	F4 _H

Table 6: Supported commands (Continued)

Command name	Command code (in hex)
Security Freeze Lock	F5 _H
Security Disable Password	F6 _H

4.1.2 Identify Device command

The Identify Device command (command code EC_H) transfers information about the drive to the host following power up. The data is organized as a single 512-byte block of data, whose contents are shown in the table on page 27. All reserved bits or words should be set to zero. Parameters listed with an “x” are drive-specific or vary with the state of the drive. See Section 2.0 on page 3 for default parameter settings.

The following commands contain drive-specific features that may not be included in the *Draft ATA-6 Standard*.

Word	Description	Value
0	Configuration information: <ul style="list-style-type: none"> • Bit 15: 0 = ATA; 1 = ATAPI • Bit 7: removable media • Bit 6: removable controller • Bit 0: reserved 	0C5A _H
1	Number of logical cylinders	16,383
2	ATA-reserved	0000 _H
3	Number of logical heads	16
4	Retired	0000 _H
5	Retired	0000 _H
6	Number of logical sectors per logical track: 63	003F _H
7–9	Retired	0000 _H
10–19	Serial number: (20 ASCII characters, 0000 _H = none)	ASCII
20	Retired	0000 _H
21	Retired	0400 _H
22	Obsolete	0000 _H
23–26	Firmware revision (8 ASCII character string, padded with blanks to end of string)	x.xx
27–46	Drive model number: (40 ASCII characters, padded with blanks to end of string)	ST94811AB
47	(Bits 7–0) Maximum sectors per interrupt on Read multiple and Write multiple (16)	8010 _H
48	Reserved	0000 _H
49	Standard Standby timer, IORDY supported and may be disabled	2F00 _H
50	ATA-reserved	0000 _H
51	PIO data-transfer cycle timing mode	0200 _H
52	Retired	0200 _H
53	Words 54–58, 64–70 and 88 are valid	0007 _H
54	Number of current logical cylinders	xxxx _H

Word	Description	Value
55	Number of current logical heads	xxxx _H
56	Number of current logical sectors per logical track	xxxx _H
57–58	Current capacity in sectors	xxxx _H
59	Number of sectors transferred during a Read Multiple or Write Multiple command	xxxx _H
60–61	Total number of user-addressable LBA sectors available (see Section 2.2 for related information)	ST94811AB = 78,140,160
62	Retired	0000 _H
63	Multiword DMA active and modes supported (see note following this table)	xx07 _H
64	Advanced PIO modes supported (modes 3 and 4 supported)	0003 _H
65	Minimum multiword DMA transfer cycle time per word (120 nsec)	0078 _H
66	Recommended multiword DMA transfer cycle time per word (120 nsec)	0078 _H
67	Minimum PIO cycle time without IORDY flow control (240 nsec)	00F0 _H
68	Minimum PIO cycle time with IORDY flow control (120 nsec)	0078 _H
69–74	ATA-reserved	0000 _H
75	Queue depth	0000 _H
76–79	ATA-reserved	0000 _H
80	Major version number	007E _H
81	Minor version number	0000 _H
82	Command sets supported	346B _H
83	Command sets supported	7D01 _H
84	Command sets support extension	4003 _H
85	Command sets enabled	34xx _H
86	Command sets enabled	3xxx _H
87	Command sets enable extension	4003 _H
88	Ultra DMA support and current mode (see note following this table)	xx3F _H
89	Security erase time	0000 _H
90	Enhanced security erase time	0000 _H
91	Advanced power management value	0040 _H
92	Master password revision code	FFFE _H
93	Hardware reset value (see description following this table)	xxxx _H
94	Auto acoustic management setting	xxxx _H
95–127	ATA-reserved	0000 _H
128	Security status	0001 _H
129–159	Seagate-reserved	xxxx _H

Word	Description	Value
160–254	ATA-reserved	0000 _H
255	Integrity word	xxA5 _H

Note. See the bit descriptions below for words 63, 88, 93 and 94 of the Identify Drive data:

Description (if bit is set to 1)

	Bit	Word 63
	0	Multiword DMA mode 0 is supported.
	1	Multiword DMA mode 1 is supported.
	2	Multiword DMA mode 2 is supported.
	8	Multiword DMA mode 0 is currently active.
	9	Multiword DMA mode 1 is currently active.
	10	Multiword DMA mode 2 is currently active.
	Bit	Word 88
	0	Ultra DMA mode 0 is supported.
	1	Ultra DMA mode 1 is supported.
	2	Ultra DMA mode 2 is supported.
	3	Ultra DMA mode 3 is supported.
	4	Ultra DMA mode 4 is supported.
	8	Ultra DMA mode 0 is currently active.
	9	Ultra DMA mode 1 is currently active.
	10	Ultra DMA mode 2 is currently active.
	11	Ultra DMA mode 3 is currently active.
	12	Ultra DMA mode 4 is currently active.
	13	Ultra DMA mode 5 is currently active.
	Bit	Word 93
	13	1 = 80-conductor cable detected, CBLID above V _{IH} 0 = 40-conductor cable detected, CBLID below V _{IL}

4.1.3 Set Features command

This command controls the implementation of various features that the drive supports. When the drive receives this command, it sets BSY, checks the contents of the Features register, clears BSY and generates an interrupt. If the value in the register does not represent a feature that the drive supports, the command is aborted. Power-on default has the read look-ahead and write caching features enabled. The acceptable values for the Features register are defined as follows:

Table 7: Features register values

02 _H	Enable write cache (<i>default</i>).	
03 _H	Set transfer mode (based on value in Sector Count register).	
	Sector Count register values:	
	00 _H	Set PIO mode to default (PIO mode 2).
	01 _H	Set PIO mode to default and disable IORDY (PIO mode 2).
	08 _H	PIO mode 0
	09 _H	PIO mode 1
	0A _H	PIO mode 2
	0B _H	PIO mode 3
	0C _H	PIO mode 4 (<i>default</i>)
	20 _H	Multiword DMA mode 0
	21 _H	Multiword DMA mode 1
	22 _H	Multiword DMA mode 2
	40 _H	Ultra DMA mode 0
	41 _H	Ultra DMA mode 1
	42 _H	Ultra DMA mode 2
	43 _H	Ultra DMA mode 3
	44 _H	Ultra DMA mode 4
	45 _H	Ultra DMA mode 5
05 _H	Enable advanced power management	
55 _H	Disable read look-ahead (read cache) feature.	
82 _H	Disable write cache.	
AA _H	Enable read look-ahead (read cache) feature (<i>default</i>).	
F1 _H	Report full capacity available	

Note. At power-on, or after a hardware or software reset, the default values of the features are as indicated above.

4.1.4 S.M.A.R.T. commands

S.M.A.R.T. provides near-term failure prediction for disc drives. When S.M.A.R.T. is enabled, the drive monitors predetermined drive attributes that are susceptible to degradation over time. If self-monitoring determines that a failure is likely, S.M.A.R.T. makes a status report available to the host. Not all failures are predictable. S.M.A.R.T. predictability is limited to the attributes the drive can monitor. For more information on S.M.A.R.T. commands and implementation, see the *Draft ATA-6 Standard*.

SeaTools diagnostic software activates a built-in drive self-test (DST S.M.A.R.T. command for D4_H) that eliminates unnecessary drive returns. The diagnostic software ships with all new drives and is also available at: <http://seatools.seagate.com>.

This drive is shipped with S.M.A.R.T. features disabled. You must have a recent BIOS or software package that supports S.M.A.R.T. to enable this feature. The table below shows the S.M.A.R.T. command codes that the drive uses.

Table 8: Supported S.M.A.R.T. commands

Code in features register	S.M.A.R.T. command
D0 _H	S.M.A.R.T. Read Data
D1 _H	Vendor-specific
D2 _H	S.M.A.R.T. Enable/Disable Attribute Autosave
D3 _H	S.M.A.R.T. Save Attribute Values
D4 _H	S.M.A.R.T. Execute Off-line Immediate (runs DST)
D5 _H	S.M.A.R.T. Read Log Sector
D6 _H	S.M.A.R.T. Write Log Sector
D7 _H	Vendor-specific
D8 _H	S.M.A.R.T. Enable Operations
D9 _H	S.M.A.R.T. Disable Operations
DA _H	S.M.A.R.T. Return Status

Note. If an appropriate code is not written to the Features Register, the command is aborted and 0x04 (abort) is written to the Error register.

5.0 Seagate Technology support services

Online Services

Internet

www.seagate.com for information about Seagate products and services. Worldwide support is available 24 hours daily by e-mail for your questions.

Presales Support: www.seagate.com/support/email/email_presales.html or DiscPresales@Seagate.com

Technical Support: www.seagate.com/support/email/email_disc_support.html or DiscSupport@Seagate.com

mySeagate

my.seagate.com is the industry's first Web portal designed specifically for OEMs and distributors. It provides self-service access to critical applications, personalized content and the tools that allow our partners to manage their Seagate account functions. Submit pricing requests, orders and returns through a single, password-protected Web interface—anytime, anywhere in the world.

reseller.seagate.com

reseller.seagate.com supports Seagate resellers with product information, program benefits and sales tools. You may register for customized communications that are not available on the web. These communications contain product launch, EOL, pricing, promotions and other channel-related information. To learn more about the benefits or to register, go to reseller.seagate.com, any time, from anywhere in the world.

Automated Phone Services

SeaFONE® (1-800-SEAGATE) is the Seagate toll-free number (1-800-732-4283) to access our automated self-help and directory assistance for Seagate support services. Using a touch-tone phone, you can find service and support phone numbers for disc drives 24 hours daily. International callers can reach this service by dialing +1-405-324-4770.

Presales, Technical Support and Warranty Service

Presales Support

Our Presales Support staff can help you determine which Seagate products are best suited for your specific application or computer system.

Technical Support

If you need help installing your drive, consult your system's documentation or contact the dealer's support services department for assistance specific to your system. Seagate technical support is also available to assist you online at support.seagate.com or through one of our call centers. Have your system configuration information and your drive's "ST" model number available.

SeaTDD™ (+1-405-324-3655) is a telecommunications device for the deaf (TDD). You can send questions or comments 24 hours daily and exchange messages with a technical support specialist during normal business hours for the call center in your region.

Warranty Service

Seagate offers worldwide customer support for Seagate drives. Seagate distributors, OEMs and other direct customers should contact their Seagate service center representative for warranty-related issues. Resellers or end users of drive products should contact their place of purchase or one of the Seagate warranty service centers for assistance. Have your drive's "ST" model number and serial number available.

Authorized Service Centers

In some locations outside the US, you can contact an Authorized Service Center for service.

USA/Canada/Latin America Support Services

Presales Support

Call Center	Toll-free	Direct dial	FAX
Americas	1-877-271-3285 ¹	+1-405-324-4730 ¹	+1-405-324-4704

Technical Support

Call Center	Toll-free	Direct dial	FAX
Americas	1-800-SEAGATE ²	+1-405-324-4700 ³	+1-405-324-4702

Warranty Service

Call Center	Toll-free	Direct dial	FAX / Internet
USA, Mexico and Latin America	1-800-468-3472 ⁴	+1-405-324-4720 ⁴	+1-405-324-4722
Canada <i>Memofix</i> ⁵	1-800-636-6349	+1-905-660-4936	+1-905-660-4951 www.memofix.com
Brazil <i>MA Centro de Serviços</i> ⁵	—	+55-21-2509-7267 www.mainformatica.com.br/produtos.htm	+55-21-2507-6672

¹Hours of operation are 8:00 A.M. to 11:45 A.M. and 1:00 P.M. to 6:00 P.M., Monday through Friday (Central time)

²For product-specific phone number

³Hours of operation are 8:00 A.M. to 8:00 P.M., Monday through Friday (Central time)

⁴Hours of operation are 8:30 A.M. to 12:15 P.M. and 1:30 P.M. to 5:30 P.M., Monday through Friday (Central time)

⁵Authorized Service Center

European Support Services

For presales and technical support in Europe, dial the toll-free number for your specific location. If your location is not listed here, dial our presales and technical support call center at +1-405-324-4714 from 8:00 A.M. to 11:45 A.M. and 1:00 P.M. to 5:00 P.M. (Central Europe time) Monday through Friday. The presales and technical support call center is located in Oklahoma City, USA.

For European warranty service, dial the toll-free number for your specific location. If your location is not listed here, dial our European warranty service center at +31-20-316-7222 from 8:30 A.M. to 5:00 P.M. (Central Europe time) Monday through Friday. The warranty service center is located in Amsterdam, The Netherlands.

Toll-Free Support Numbers

Call Center	Presales and Technical Support	Warranty Service
Austria	0 800-20 12 90	0 800-20 12 90
Belgium	00 800-47324283 (00 800-4SEAGATE)	00 800-47324289
Denmark	00 800-47324283	00 800-47324289
France	00 800-47324283	00 800-47324289
Germany	00 800-47324283	00 800-47324289
Ireland	00 800-47324283	00 800-47324289
Italy	00 800-47324283	00 800-47324289
Netherlands	00 800-47324283	00 800-47324289
Norway	00 800-47324283	00 800-47324289
Poland	00 800-311 12 38	00 800-311 12 38
Spain	00 800-47324283	00 800-47324289
Sweden	00 800-47324283	00 800-47324289
Switzerland	00 800-47324283	00 800-47324289
Turkey	00 800-31 92 91 40	00 800-31 92 91 40
United Kingdom	00 800-47324283	00 800-47324289

FAX Services—All Europe (toll call)

Technical Support	+1-405-324-4702
Warranty Service	+31-20-653-3513

Africa/Middle East Support Services

For presales and technical support in Africa and the Middle East, dial our presales and technical support call center at +1-405-324-4714 from 8:00 A.M. to 11:45 A.M. and 1:00 P.M. to 5:00 P.M. (Central Europe time) Monday through Friday. The presales and technical support call center is located in Oklahoma City, USA.

For warranty service in Africa and the Middle East, dial our European warranty service center at +31-20-316-7222 from 8:30 A.M. to 5:00 P.M. (Central Europe time) Monday through Friday, or send a FAX to +31-20-653-3513. The warranty service center is located in Amsterdam, The Netherlands.

Asia/Pacific Support Services

For Asia/Pacific presales and technical support, dial the toll-free number for your specific location. The Asia/Pacific toll-free numbers are available from 6:00 A.M. to 10:45 A.M. and 12:00 P.M. to 6:00 P.M. (Australian Eastern time) Monday through Friday, except as noted. If your location is not listed here, direct dial one of our technical support locations. Warranty service is available from 9:00 A.M. to 6:00 P.M. April through October, and 10:00 A.M. to 7:00 P.M. November through March (Australian Eastern time) Monday through Friday.

Call Center	Toll-free	Direct dial	FAX
Australia	1800-14-7201	—	—
China (Mandarin) ^{1, 4}	800-810-9668	+86-10-6225-5336	—
Hong Kong	800-90-0474	—	—
Hong Kong (Cantonese) ^{1, 4}	001-800-0830-1730	—	—
India ^{2, 4}	1-600-33-1104	—	—
Indonesia	001-803-1-003-2165	—	—
Japan ^{3, 4}	0034 800 400 554	—	—
Malaysia	1-800-80-2335	—	—
New Zealand	0800-443988	—	—
Singapore	800-1101-150	—	+65-6488-7525
Taiwan (Mandarin) ^{1, 4}	00-800-0830-1730	—	—
Thailand	001-800-11-0032165	—	—

Warranty Service

Call Center	Toll-free	Direct dial	FAX
Asia/Pacific	—	+65-6485-3595	+65-6485-4860
Australia	1800-12-9277	—	—
India ⁴	—	+91-44-821-6164	+91-44-827-2461

¹Hours of operation are 8:30 A.M. to 5:30 P.M., Monday through Friday (Australian Western time).

²Hours of operation are 9:00 A.M. to 6:00 P.M., Monday through Saturday.

³Hours of operation are 9:30 A.M. to 6:30 P.M., Monday through Friday (Japan time).

⁴Authorized Service Center

Index

Numerics

3D Defense System 1

A

acoustics 11
agency certification (regulatory) 12
altitude 9
ambient conditions 3
ambient temperature 6, 9
areal density 1, 5
ATA interface 17
ATA-standard commands 18
Australian C-Tick 13
autodetection 1
average seek time 6

B

BPI 5
buffer 5
burst 1

C

cable select 1
cable-select option 16
cache 1, 5
case temperature 9
CE mark 12
certification 12
Check Power Mode 19
commands 18
compliance 12
conducted noise 8
conducted RF immunity 11
configuring the drive 15
connector pins 17
CSA C22.2 (950) 12
CSEL 16
C-Tick 13
current profile 8
cycles 12

D

Data Defense 1
data-transfer rates 1
DC power 7
density 5
Diagnostic Defense 1
diagnostic software 1, 24
discs 5
dissipation 7

Download Microcode 18
Drive Defense 1
drive diagnostics 6
drive monitoring 1
drive self-test 1, 24
DST 24

E

electrical fast transient 11
electromagnetic compatibility 12
Electromagnetic Compatibility Directive 12
electromagnetic immunity 11
electrostatic discharge 11
EMC compliance 12
EN 60950 12
enclosures 13
environmental specifications 9
EPRML 1
error-correction algorithms 1
errors 12
European Union 12
Execute Device Diagnostics 18

F

failure prediction 24
FCC verification 13
Features register 23
Flush Cache 18
Flush Cache Extended 18
formatted capacity 5
frequency 11

G

GMR 1
guaranteed sectors 5

H

handling 15
heads 1, 5
height 6
humidity 9

I

I/O data-transfer rate 5
Identify Device 18
Identify Device command 20
Idle 7, 19
Idle Immediate 19
Idle mode power 7
IEC950 12
Information Technology Equipment 12
Initialize Device Parameters 18
interface 5, 17

- interface signals 17
- interference 13
- interleave 5
- internal data-transfer rate OD 5
- ISO document 7779 11

J

- jumper settings 15

K

- Korean RRL 13

L

- LBA mode 5
- length 6
- Load/Unload 12
- logical geometry 5

M

- master/slave 1
- Master/slave configuration 15
- maximum temperature 9
- Mean time between failures (MTBF) 12
- modes 17
- monitoring 1
- mounting the drive 15, 16

N

- noise 8
- nominal power 3
- nonoperating shock 10
- nonoperating vibration 10
- nonrecoverable read errors 12

O

- operating 7
- operating power and current 7
- operating shock 10
- operating vibration 10

P

- physical characteristics 6
- physical organization 5
- pins 17
- PIO 17
- power consumption 7
- power dissipation 7
- power on/off cycles 12
- power specifications 7
- power-management commands 19
- Power-on to Ready 6
- precautions 16

R

- radiated RF immunity 11
- radio and television interference 13
- radio frequency (RF) 11
- random track location 7
- Read Buffer 18
- Read DMA 18
- Read DMA Extended 18
- read errors 12
- Read Multiple 1, 18
- Read Multiple Extended 18
- Read Native Max Address 18
- Read Native Max Address Extended 18
- Read Sectors 18
- Read Sectors Extended 18
- Read Verify Sectors 18
- Read Verify Sectors Extended 18
- read/write heads 5
- read/write power and current 7
- recording and interface technology 5
- recording density 5
- recording heads 1
- recording method 5
- register 23
- relative humidity 9
- reliability 12
- resistance 8
- RF 11

S

- S.M.A.R.T. 19
- S.M.A.R.T. commands 24
- S.M.A.R.T. drive monitoring 1
- safety certification 12
- screws 16
- SeaTools 1, 24
- sectors 5
- security commands 19
- Security Disable Password 20
- Security Erase Prepare 19
- Security Erase Unit 19
- Security Freeze Lock 20
- Security Set Password 19
- Security Unlock 19
- Seek 19
- seek mode 7
- seek time 6
- Seeking 7
- Service Life 12
- servo electronics 7
- Set Features 19
- Set Features command 23
- Set Max 19
- Set Multiple Mode 19

- shock 10
- signals 17
- single-track seeks 6
- Sleep 7, 19
- sound 11
- specifications 3
- spindle speed 5
- Spinup 7
- spinup power 7
- Standby 7, 19
- Standby Immediate 19
- Standby mode 7
- Standby to Ready 6
- static-discharge precautions 15
- subassembly 13
- support services 25
- surge immunity 11

T

- technical support services 25
- temperature 9
- temperature gradient 9
- time to ready 6
- track density 5
- track-to-track seek time 6
- TUV North America 12

U

- UL 1950 12

V

- vibration 10
- voltage 8
- voltage dips, interrupts 11
- voltage tolerance 8

W

- Warranty 12
- weight 6
- wet bulb temperature 9
- width 6
- Write Buffer 19
- Write DMA 19
- Write DMA Extended 19
- Write Multiple 1, 19
- Write Multiple Extended 19
- Write Sectors 19
- Write Sectors Extended 19



Seagate Technology LLC
920 Disc Drive, Scotts Valley, California 95066-4544, USA
Publication Number: 100339697, Rev. A, Printed in USA